

D2E160-AH02-15

AC centrifugal fan

forward curved, dual inlet
with housing (without flange)

www.invotric.com

invotric@gmail.com

Nominal data

Type	D2E160-AH02-15		
Motor	M2E074-LA		
Phase		1~	1~
Nominal voltage	VAC	230	230
Frequency	Hz	50	60
Type of data definition		ml	ml
Valid for approval / standard		-	-
Speed	min ⁻¹	2500	2400
Power input	W	550	730
Current draw	A	2.45	3.2
Motor capacitor	μF	12	12
Capacitor voltage	VDB	400	400
Min. back pressure	Pa	400	390
Min. ambient temperature	°C	-25	-25
Max. ambient temperature	°C	90	50

ml = Max. load · me = Max. efficiency · fa = Running at free air · cs = Customer specs · cu = Customer unit
Subject to alterations

D2E160-AH02-15

AC centrifugal fan

forward curved, dual inlet
with housing (without flange)

Technical features

Mass	9.7 kg
Size	160 mm
Surface of rotor	Coated in black
Material of impeller	Sheet steel, hot-galvanised
Housing material	Sheet steel, hot-galvanised
Material of guard grille	Steel, phosphated and plastic-coated in white aluminium (RAL 9006)
Motor suspension	Motor mounted vibration-free on both sides
Direction of rotation	Counter-clockwise, seen on rotor
Type of protection	IP 00
Insulation class	"F"
Humidity class	F2-1
Max. permissible ambient motor temp. (transp./ storage)	+ 80 °C
Min. permissible ambient motor temp. (transp./storage)	- 40 °C
Mounting position	Shaft horizontal
Condensate discharge holes	None, open rotor
Operation mode	S1
Motor bearing	Ball bearing
Touch current acc. IEC 60990 (measuring network Fig. 4, TN system)	< 0.75 mA
Electrical leads	Via terminal strips, integrated capacitor connected via terminal strips
Motor protection	Thermal overload protector (TOP) brought out
Cable exit	Axial
Protection class	I (if protective earth is connected by customer)
Product conforming to standard	EN 60335-1
Approval	CCC

D2E160-AH02-15

AC centrifugal fan

forward curved, dual inlet
with housing (without flange)

Product drawing

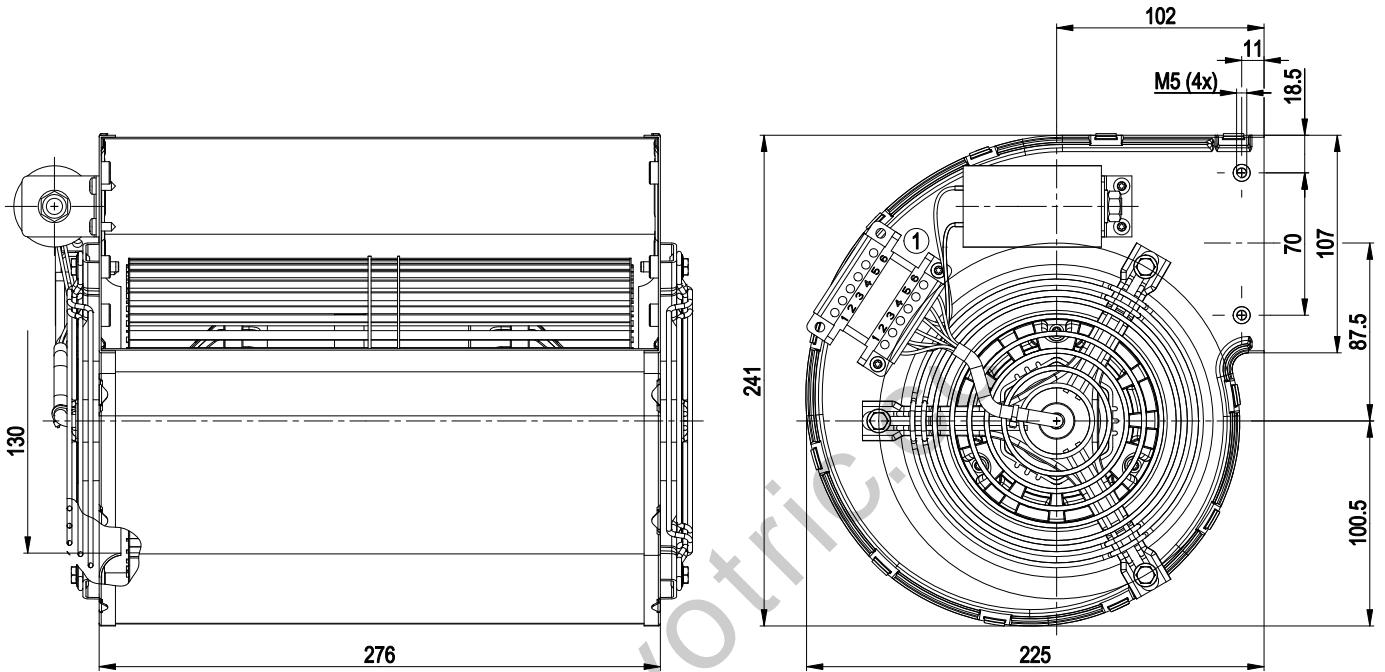

No.	Pin	Signal	Function / assignment
1			Strip Weidmüller 1612070000 & socket connector Weidmüller 1612080000
			Terminal assignment:
	1	PE	green/yellow
	2		brown + capacitor
	3	L	blue
	4	N	black + capacitor
	5	TOP	grey
	6	TOP	grey

D2E160-AH02-15

AC centrifugal fan

forward curved, dual inlet
with housing (without flange)

Connection screen

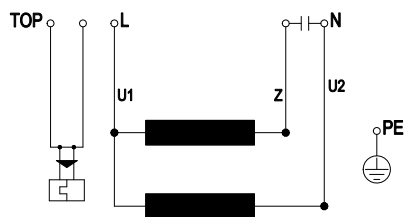

TOP	2 x grey	U1	blue	Z	brown
U2	black	PE	green / yellow		

www.invotric.cc

AC centrifugal fan

forward curved, dual inlet
with housing (without flange)

Charts: Air flow 50 Hz

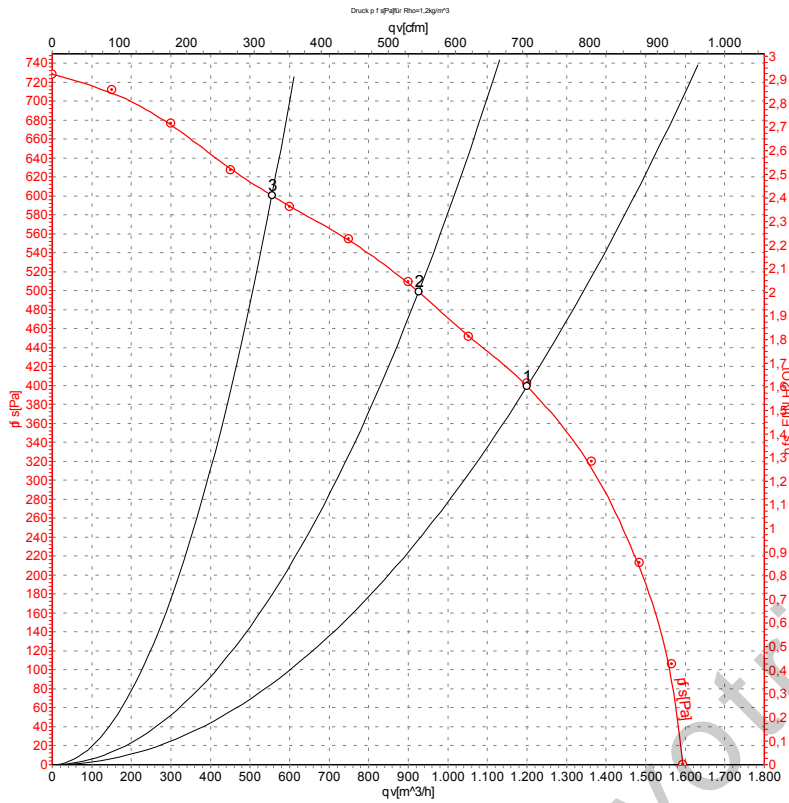

Measurement: LU-109474

Air performance measured as per ISO 5801 Installation category A. For detailed information on the measuring set-up, please contact ebm-papst. Suction-side noise levels: L_{wA} measured as per ISO 13347 / L_{pA} measured with 1m distance to fan axis. The values given are valid under the measuring conditions mentioned above and may vary according to the actual installation situation. With any deviation from the standard set-up, the specific values have to be checked and reviewed with the unit installed.

Measured values

	U	f	n	P _e	I	qv	P _{fs}
	V	Hz	min ⁻¹	W	A	m ³ /h	Pa
1	230	50	2500	550	2.45	1200	400
2	230	50	2630	515	2.35	925	500
3	230	50	2715	456	2.18	555	600

U = Supply voltage · f = Frequency · n = Speed · P_e = Power input · I = Current draw · qv = Air flow · p_{fs} = Pressure increase

AC centrifugal fan

forward curved, dual inlet
with housing (without flange)

Charts: Air flow 60 Hz

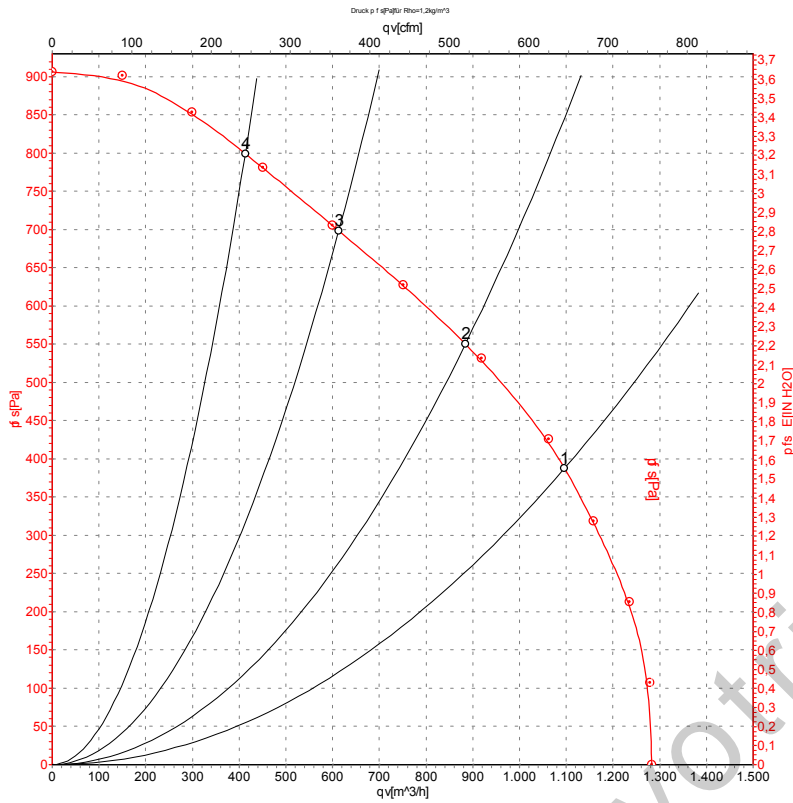

Measurement: LU-109478

Air performance measured as per ISO 5801 Installation category A. For detailed information on the measuring set-up, please contact ebm-papst. Suction-side noise levels: L_{wA} measured as per ISO 13347 / L_{pA} measured with 1m distance to fan axis. The values given are valid under the measuring conditions mentioned above and may vary according to the actual installation situation. With any deviation from the standard set-up, the specific values have to be checked and reviewed with the unit installed.

Measured values

	U	f	n	P _e	I	qv	P _{fs}
	V	Hz	min ⁻¹	W	A	m ³ /h	Pa
1	230	60	2400	730	3.20	1095	390
2	230	60	2715	698	3.05	885	550
3	230	60	2940	663	2.94	615	700
4	230	60	3050	640	2.88	415	800

U = Supply voltage · f = Frequency · n = Speed · P_e = Power input · I = Current draw · qv = Air flow · P_{fs} = Pressure increase